

# Minotti

## ALLEN DESIGN RODOLFO DORDONI



Il divano Allen esprime perfettamente quello che Minotti intende per "divano". È caratterizzato dalla leggerezza delle linee e delle proporzioni, da un'elevata altezza da terra e dalla razionalità dei volumi, senza rinunciare però alle forme morbide e alle rotondità, dei braccioli in particolare. Pur essendo un prodotto di design, Allen non rinuncia al comfort, grazie allo schienale alto che consente l'appoggio totale sia per la schiena che per la testa. La parte imbottita interna del bracciolo e dello schienale è realizzata con uno stampo, mentre il sedile reversibile è rivestito in piuma d'oca. I piedini, realizzati con stampo per fusione in alluminio, sono caratterizzati dal design sinuoso e testimoniano come il concetto di classicità sia proprio del DNA Minotti.

**Struttura:** in legno multistrati con molleggio garantito da cinghie elastiche ad alta componente di caucciù. Traversi di rinforzo in metallo.

**Preparazione della struttura:** in poliuretano espanso a quote differenziate ad alta densità. Imbottitura bracciolo e schienale realizzata con inserto schiumato ignifugo con quota morbida per conferire comfort e sofficià. Ulteriore rivestimento in fibra termolegata di forte spessore ed accoppiata con tela di cotone bianca.

**Cuscineria:** imbottitura cuscino seduta in piuma d'oca canalizzata con inserto centrale in poliuretano espanso ad alta resilienza. Cuscini schienale totalmente imbottiti in piuma d'oca canalizzata.

**Piedini:** appoggio a terra tramite piedini (disegno esclusivo Minotti Studio) stampati in alluminio pressofuso e verniciati color Peltro con finitura extra-lucida anti-touch. Scivolante protettivo in Hytrel® (gomma morbida antigraffio).

**Sfoderabilità:** rivestimento sfoderabile solo in tessuto. Rivestimento in pelle fisso solo per la struttura, cuscini schienale e seduta sfoderabili.

The Allen sofa is a perfect example of what Minotti means by "sofa": an object defined by its smooth lines and proportions, its added height from the floor, and the functionality of its dimensions, without sacrificing soft lines and rounded shapes, especially where the arms are concerned. Even though it's a product of design, Allen is certainly not lacking in comfort, thanks to the high back that offers total support for the back and the head. Internal padding of the arms and back is molded, while the reversible seat cushion is covered in goose down. The feet, made of molded, die cast aluminium, describe a sinuous line, proof that the classical concept is inherent to Minotti's DNA.

**Frame:** multi-ply wood frame with seating suspension guaranteed by elastic straps with a high rubber content. Metal reinforcements set crosswise.

**Frame preparation:** let into high-density polyurethane foam in different densities. Arm and backrest padding with soft fireproof foam insert for enhanced softness and comfort. Additional thick fiber lining thermally bound to a white canvas.

**Cushions:** channeled goose down filling for the seat cushions with very resilient polyurethane foam central insert. Channeled goose down for the backrest cushions.

**Feet:** molded aluminium die-cast feet (exclusive design by Minotti Studio), Pewter coloured paint with extra-glossy anti-touch finish. Protective Hytrel® (soft scratchproof rubber) glide.

**Cover:** fully removable fabric covers. Non-removable leather for the frame, removable leather backrest and seat cushion covers.

Das Sofa Allen ist der perfekte Ausdruck des wahren Konzepts eines "Sofas", wie es Minotti versteht. Es zeichnet sich durch die Leichtigkeit der Linien und Proportionen aus, durch viel Bodenfreiheit und rationelle Volumen, ohne jedoch auf die weich gerundeten Formen, vor allem bei den Armlehnen, zu verzichten. Allen ist ein Designprodukt, das aber mit der hohen Lehne, die Rücken und Kopf ruhen lässt, vollen Komfort garantiert. Die gepolsterten Teile, die Innenseite der Arm- und Rückenlehne, sind formgepresst, während die beidseitig benutzbaren Sitzflächen mit Gänsedaunen bezogen sind. Die FüÙe aus Aluminiumdruckguss zeichnen sich durch ihr geschwungenes Design aus, ein präziser Hinweis auf die klassische Komponente im DNA der Firma Minotti.

**Struktur:** aus Schichtholz, Federung garantiert mit elastischen Riemen mit hohem Kautschukanteil. Metallquerstreben.

**Aufbereitung des Gestells:** unterschiedlich dick geschäumtem, hochdichtem Polyurethan. Arm- und Rückenlehne mit feuerfester, besonders weicher Schaumeinlage, die Komfort und Schmiegsamkeit garantiert. Weitere Beschichtung mit extradicker, wärmesensibler Faser kombiniert mit weißem Baumwolltuch.

**Kissen:** Sitzkissen mit kanalisierter Daunenfüllung mit zentraler Einlage aus hochelastischem PU-Schaum. Kissen der Rückenlehne mit kanalisiert belüfteter Daunenfüllung.

**FüÙe:** Bodenaufgabe durch FüÙe aus Aluminiumpressguss (exklusives Minotti-Design), Zinnfarben hochglanzlackiert mit Schutzbeschichtung gegen Abdrücke. Gleitschutz durch Hytrel® (weicher, kratzfester Gummi).

**Abziehbarkeit:** Nur der Stoffbezug ist abziehbar. Fester Kernlederbezug nur am Gestell, Sitz- und Rückenkissen sind abziehbar.

Le canapé Allen exprime parfaitement ce que Minotti entend par "canapé". Il se caractérise par la légèreté de ses lignes et de ses proportions, par sa hauteur élevée du sol et la rationalité de ses volumes, sans toutefois renoncer aux formes souples et aux rondeurs, notamment des accoudoirs. Tout en étant un produit de design, Allen ne renonce pas au confort, grâce à son dossier haut permettant d'appuyer totalement le dos et la tête. La partie rembourrée interne de l'accoudoir et du dossier est réalisée à l'aide d'un moule, tandis que l'assise réversible est en plume d'oie. Les pieds, réalisés à l'aide d'un moule pour fusion en aluminium, sont caractérisés par un design sinueux et témoignent combien le concept de classicisme est génétique chez Minotti.

**Structure :** en bois contreplaqué, suspension garantie par des courroies élastiques à teneur élevée en caoutchouc. Traverses de renfort en métal.

**Préparation de la structure :** en polyuréthane expansé à hauteurs différenciées et haute densité. Rembourrage des accoudoirs et du dossier réalisé avec un insert en mousse ignifuge à hauteur souple pour donner confort et moelleux. Ulérieur revêtement en fibre thermoliée de forte épaisseur et couplé à de la toile de coton blanche.

**Coussins :** rembourrage du coussin de l'assise en plume d'oie canalisée, avec insert central en polyuréthane expansé à haute résilience. Coussins du dossier entièrement rembourrés en plume d'oie canalisée.

**Pieds :** pieds d'appui au sol (dessin exclusif Minotti Studio) estampés en aluminium moulé sous pression et peints couleur Étain, finition ultrabrillant anti-trace de doigts. Patin de protection en Hytrel® (gomme souple anti-rayure).

**Déhoussage :** seul le revêtement en tissu est déhoussable. Le revêtement en cuir de la structure est fixe, celui de coussins, dossier et assise est déhoussable.

## PIEDINO | FOOT



# Minotti

## DIVANO | SOFA

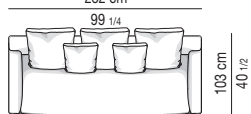
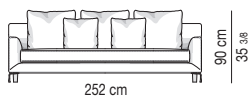
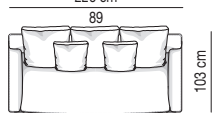
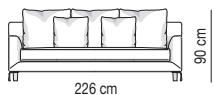
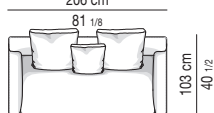
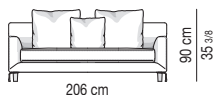
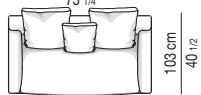
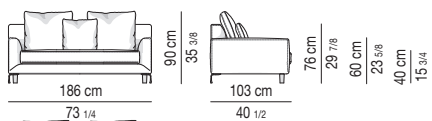

## DIVANO COMPOSTO | TWO ELEMENTS SOFA

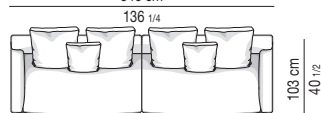
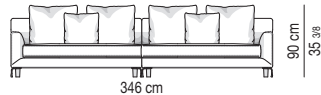
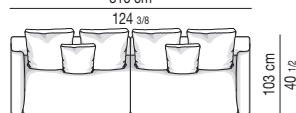
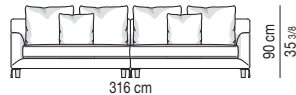
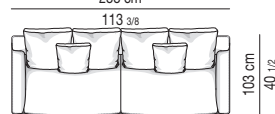

## ELEMENTO CENTRALE | CENTRAL ELEMENT

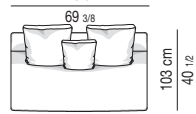
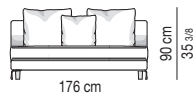
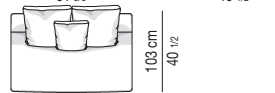
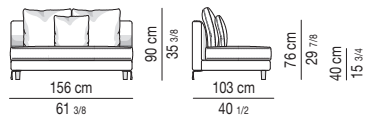

# Minotti

## ELEMENTO TERMINALE | ELEMENT WITH 1 ARM

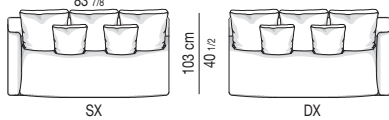
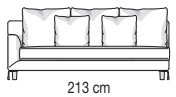
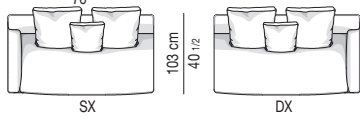
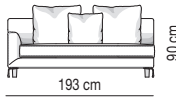
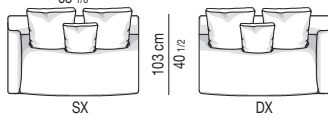
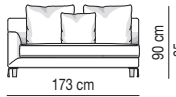
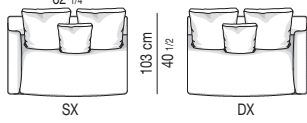
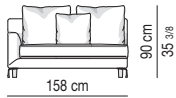
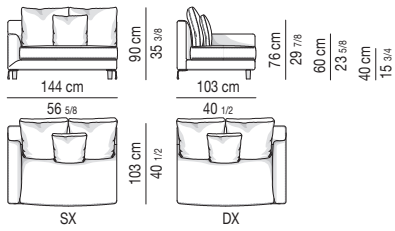

## CHAISE LONGUE

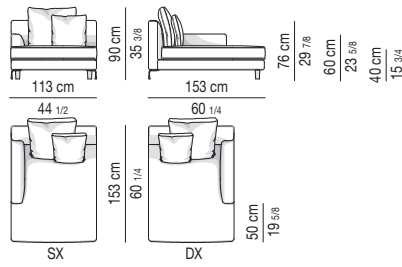

## DIVANO CHAISE LONGUE | SOFA-CHAISE LONGUE

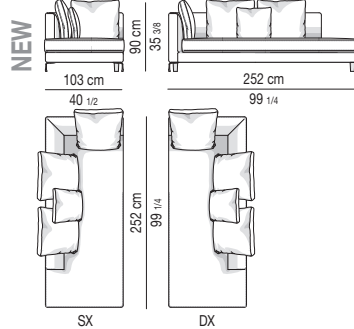
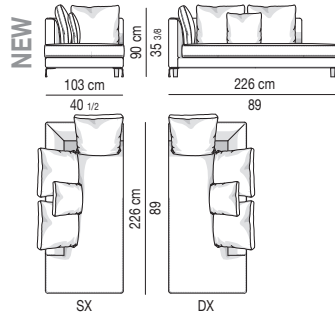

## DIVANO-CHAISE LONGUE TERMINALE SOFA-CHAISE LONGUE WITH 1 ARM

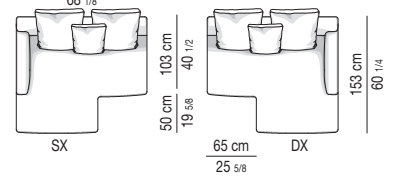
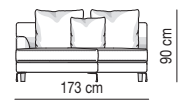
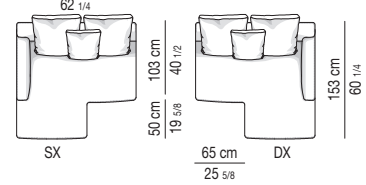
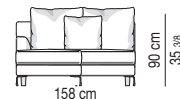
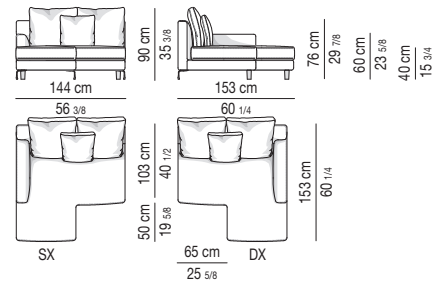

# Minotti

## DIVANO ANGOLARE | CORNER SOFA

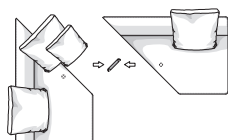
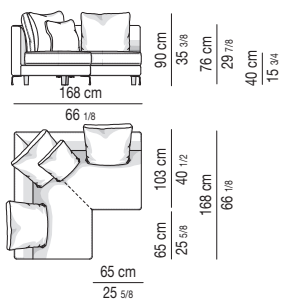

IL DIVANO ANGOLARE CM 168X168 È COMPOSTO DA 2 ELEMENTI UNITI TRA LORO TRAMITE UN SISTEMA DI AGGANCIO.

THE CORNER SOFA CM 168X168 IS COMPOSED OF 2 ELEMENTS CONNECTED THROUGH LINKING DEVICE.

## DIVANO ANGOLARE CON PENISOLA CORNER SOFA WITH OPEN ELEMENT

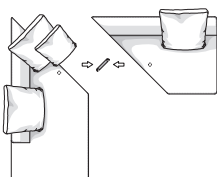
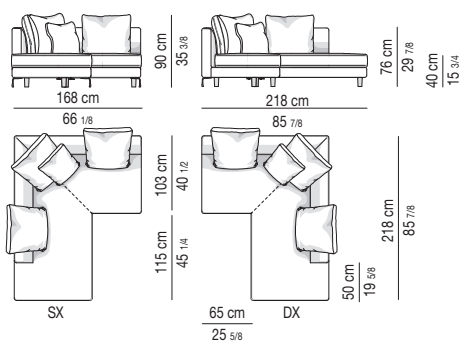

IL DIVANO ANGOLARE CON PENISOLA CM 168X218 È COMPOSTO DA 2 ELEMENTI UNITI TRA LORO TRAMITE UN SISTEMA DI AGGANCIO.

THE CORNER SOFA WITH OPEN ELEMENT CM 168X218 IS COMPOSED OF 2 ELEMENTS CONNECTED THROUGH LINKING DEVICE.

## SOFA PENISOLA SENZA BRACCIOLO OPEN-END SOFA WITHOUT ARMREST

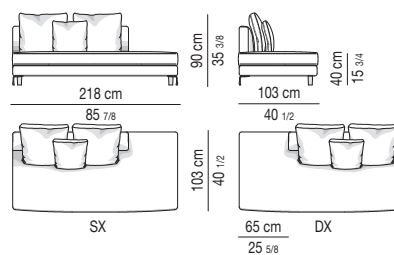

## SOFA PENISOLA CON BRACCIOLO OPEN-END SOFA WITH ARMREST

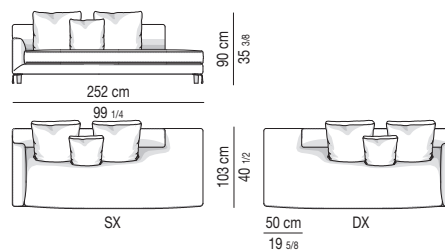
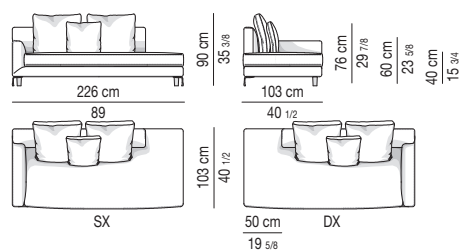

## POUF | STOOL

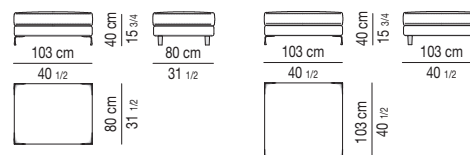

## CUSCINO OPTIONAL | OPTIONAL CUSHION

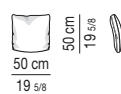



## HIGHLIGHTS

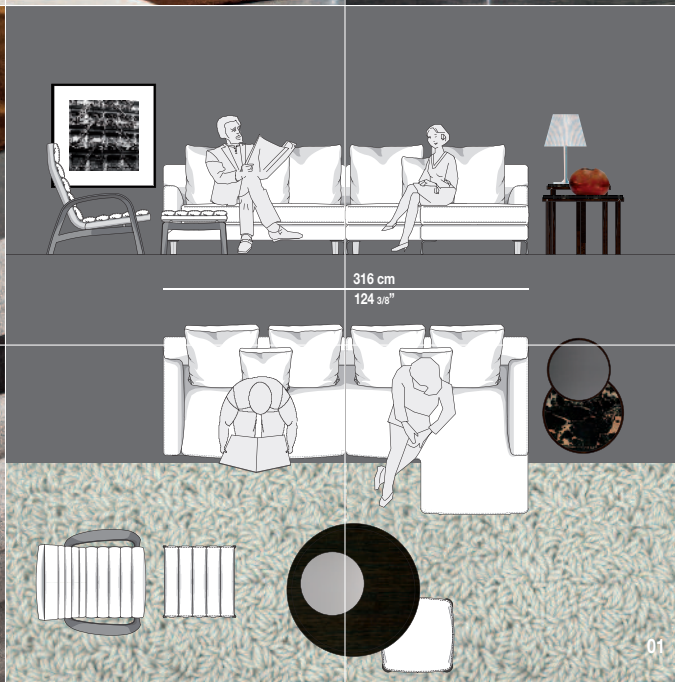
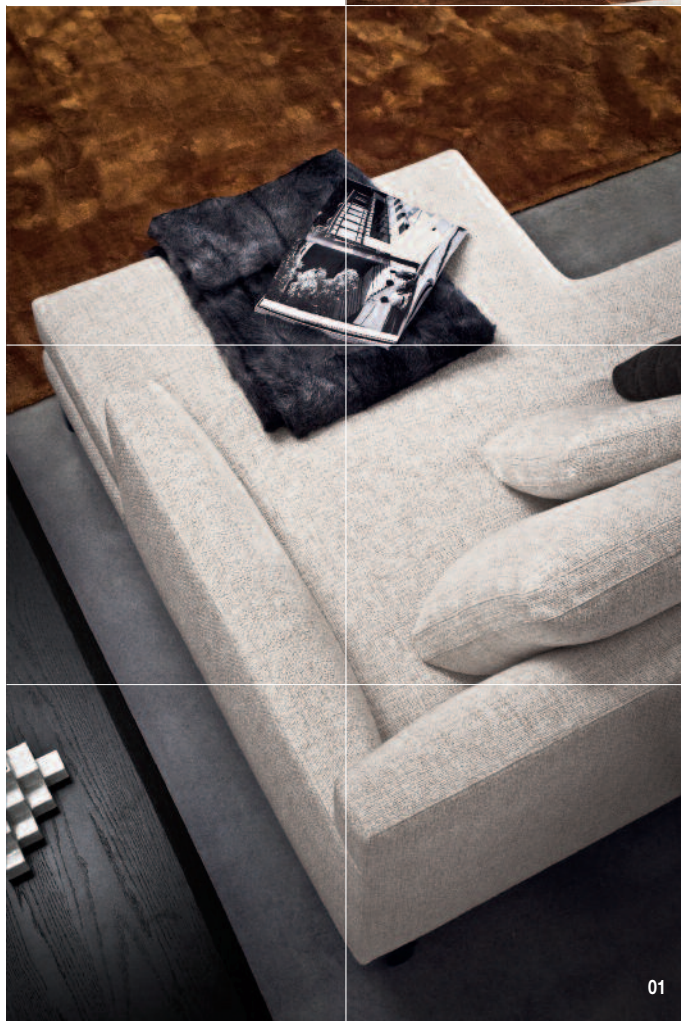

**01 Nuova formula progettuale:** a differenza delle chaise longue tradizionali che vanno in appoggio all'elemento terminale per creare una composizione, l'elemento "divano-chaise longue terminale" ha già nella sua forma un "accenno" di divano. Grazie al suo disegno a "L", lo anticipa e lo continua. Minotti risolve inoltre l'incrocio dei piedini nell'angolo e salva la pulizia del design. Un senso di chiarezza che esalta il valore del prodotto in un contesto chiave della casa: il luogo della socializzazione con gli amici, il luogo dell'intimità della famiglia.

**Totally new design concept:** unlike traditional chaise longue that form the end unit of a seating composition, the element "sofa-chaise longue with 1 arm" already possesses a "hint" of the sofa in its shape. Thanks to its "L-shaped" design, it foreshadows the sofa and carries it forward. Minotti also solves the problem of overlapping feet in the corner, and preserves the purity of design. A sense of clarity enhances the value of this piece in a key area of home living - the place for socializing with friends and enjoying family companionship.

**02 Piedini in primo piano:** di alluminio pressofuso verniciato color Peltro (tonalità ideata da Minotti Studio) hanno linee sinuose e articolazione classica per proporzioni e materia. Realizzati a stampo, sono frutto di ricerca tecnologica e amplificano il senso dell'unicità Minotti. Quanto alla loro posizione, si legge il profilo quando si guarda il divano frontalmente, mentre si coglie la superficie piatta quando si guarda il divano lateralmente o da dietro.

**Spotlight on feet:** made of die cast aluminium, in Pewter colour (a shade created by Minotti Studio) they have sinuous lines and classic structure, in both proportions and materials. Molded, they are the result of technological research and reinforce the association between Minotti and uniqueness. In terms of foot placement, they're seen in profile when the sofa is viewed from the front, while the flat surface is visible when the sofa is viewed from the back or side.